

TechTopics Topic: Fan-Cooling Control Circuit for Forced-Air Cooled Circuit Breakers

Fan cooling is a commonly used means to increase the continuous load capability of power transformers and has been used for decades. Fan cooling is appropriate when the extra capacity available in the transformer is needed only during non-routine operating circumstances, or when abnormal conditions prevail.

An example of non-routine operating circumstances is the use of fan cooling of transformers in a double-ended substation configuration. This allows one transformer to handle the entire load of the substation when one of the transformers is out of service and the tie circuit breaker is closed.

An example of abnormal conditions is the need to cope with very heavy loads often present during extremely hot weather. When a record heat wave happens, air conditioning and chiller loads increase, and the transformer can safely bear the increased loading if it is within the fan cooled rating of the transformer.

In either of these situations, fan cooling of the transformer is used to meet unusually high loading conditions that only happen occasionally, perhaps a few days a year. Fan cooling is an economic way to handle these short-term loading situations without undue investment in facilities.

Similar thoughts apply to the use of fan cooling for circuit breakers in metal-clad switchgear. Fan cooling of circuit breakers in metal-clad switchgear has been used for decades to accommodate heavy loading for relatively short periods, i.e., a few hours or a few days. Fan cooling is most commonly used to match the current-carrying capability of secondary main circuit breakers to the load capability of the associated upstream power transformer when the transformer is operating in the forced-air cooling mode.

One major difference between the application of fan cooling to transformers and to switchgear concerns losses. In both transformers and switchgear, increasing the current increases the losses as the square of the current. However, the order of magnitude of the losses in switchgear compared to power transformers is radically different. Thus, use of fan cooling for circuit breakers in switchgear does not incur the steep energy cost penalty that occurs with use of the fan-cooled rating of a transformer.

Because the penalty associated with losses is much lower for fan-cooled circuit breakers than for fan-cooled transformers, use of fan cooling of circuit breakers for long durations is not of concern. The circuit breaker is capable of operating in its fan-cooled mode at rated current indefinitely.

The typical control schematic that we use for the fan cooling circuit of the circuit breaker is shown on the following page. The operation of the control circuit is as follows:

- The forced-air fan is controlled by a single phase overcurrent relay (51), normally connected to a CT in phase 2 of the primary circuit. The overcurrent relay should be set to pickup at a reasonable current value. We prefer that the pickup be approximately 90-95% of the self-cooled continuous current capability of the circuit breaker.
- The overcurrent relay (51) normally-open contact actuates timer (TD2). In turn, timer (TD2) energizes auxiliary contactor (X) which energizes the fan itself. Timer (TD2) is an instantaneous pickup timer, with time delay dropout. The dropout time delay allows the fan to continue running for a time after the load

current through the circuit breaker drops below the dropout set point of the overcurrent relay (51). This allows for the removal of any residual heat in the circuit breaker. The time delay also allows for a “ride through” on the fan in the event of fluctuating currents. If the current is only below the set point of the overcurrent relay (51) for a few minutes and then rises again, the fan continues to run through the whole period.

- The time delay for starting of the fan is controlled by the overcurrent relay. A setting of 5 seconds delay on the overcurrent relay is common.
- The overcurrent relay normally-closed contact is connected to a timer (TD1), which is set to provide a time delay on dropout. When the overcurrent relay contact opens, TD1 drops out after a time delay. The timer typically has an adjustment range of 5-100 seconds and a setting of 30 seconds is appropriate. Thus, when the timer times out, TD1 drops out, closing the TD1 contact in the alarm circuit.

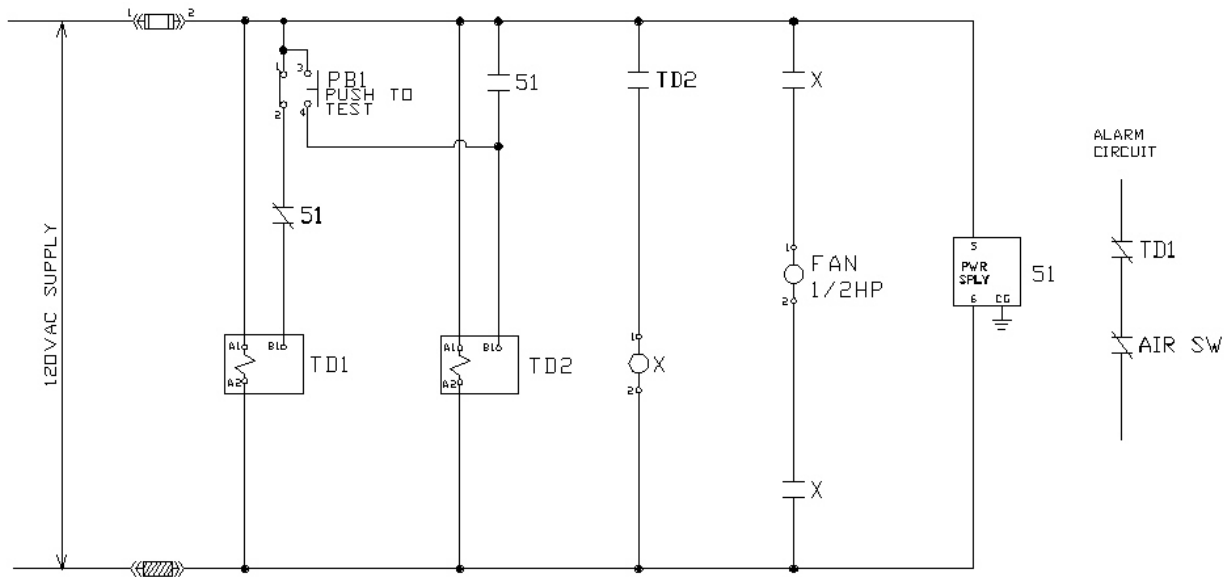

Typical Fan-Cooling Control Circuit Schematic Diagram

- The normally closed contact of timer (TD1) is connected in series with a normally closed contact from an air flow switch (AIRSW). This circuit is provided to activate a remote alarm in the event that the scheme calls for the fan to start but air flow does not occur in the time delay period set on timer TD1. The alarm circuit also is actuated on loss of control power to the fan circuit.
- A push-to-test circuit is provided with PB1. This allows for exercising of the fan scheme. The test circuit operates through TD2, which is an instantaneous pickup, time delay dropout device. When the pushbutton is depressed, the fan starts immediately. When the pushbutton is released, the fan continues to run until the dropout time on TD2 is reached. The test circuit checks the whole system beyond the current relay. The pushbutton also opens the supply to the alarm circuit, so that the alarm circuit is also tested if the pushbutton is depressed for a period longer than the dropout time of timer TD1.

T. W. (Ted) Olsen
Manager, Technology