

TechTopics Topic: Bus Joint Fundamentals

Proper design of bus bar joints is a necessity for long equipment life. The objectives that a good bolted bus bar joint must fulfill include:

- It must provide good conductivity, so that the bus system will meet the temperature rise requirements in the ANSI standards.
- It must withstand thermal cycling, so that the low resistance joint will be maintained for the life of the equipment.
- The joint pressure should be high (for good conductivity), but not so high that cold flow of the bus material occurs, which would cause the joint to deteriorate with time.
- The joint should have good resistance to corrosion in normal installation environments.
- It must be able to withstand the mechanical forces and thermal stresses associated with short-circuit conditions.

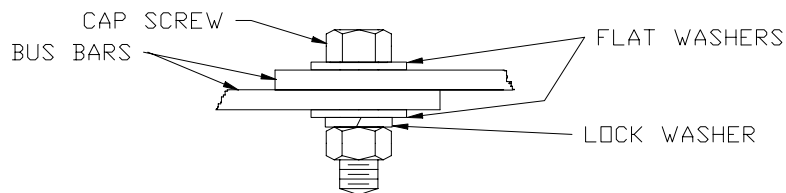

Figure 1: Anatomy of a bolted bus bar joint

Figure 1 shows a bolted bus bar joint, simplified to show two bus bars connected using a single bolt. Except in rare situations, the bus bars are silver plated (standard) or tin plated (optional), to improve the resistance to corrosion. The bolt is a high strength grade 5 cap screw, while the nut is a grade 2 (heavy wall) nut. The joint includes a large diameter, thick flat washer on both sides of the joint, adjacent to the bus bars. A split lock washer is installed under the nut to assure that the joint stays tight over the life of the equipment.

Why do we use a grade 2 nut with a grade 5 bolt? The grade 2 nut is more ductile than the grade 5 bolt, so that when the nut is torqued in place, the threads in the nut will tend to be swaged down and burnished to a degree, which results in a more equal distribution of load on all threads. This spreads the force more evenly and avoids unacceptable stress levels in the bolt and the nut.

Some users request that special non-magnetic hardware be used in bus joints. Historically, particularly in open bus systems exposed to the weather, difficulties were encountered with corrosion, and this may be one reason that some still ask for non-magnetic hardware. Others prefer non-magnetic hardware because of the perception that it results in a lower temperature rise. While these reasons may have had merit decades ago, we feel they are unnecessary today. Non-magnetic hardware (usually stainless steel or silicon bronze) is expensive and difficult to obtain. In addition, the tensile strength and yield strength of non-magnetic hardware is lower than that of high strength steel, so that tightening torques will generally be lower with the special hardware. The net effect of lower torque and pressure may very well counterbalance any slight temperature rise benefit associated with non-magnetic hardware.

We also specify that the flat washers are to have larger diameter and greater thickness than standard washers. The purpose of the washers is to distribute the clamping force of the bolts over a wider area. To accomplish this, we need a washer that is relatively rigid, with a larger diameter than would be normal for the size bolt used. If a normal small diameter, thin washer (or worse, none at all) is used, the joint will deteriorate over time because of cold flow of copper from the high pressure region directly under the bolt head (or the nut).

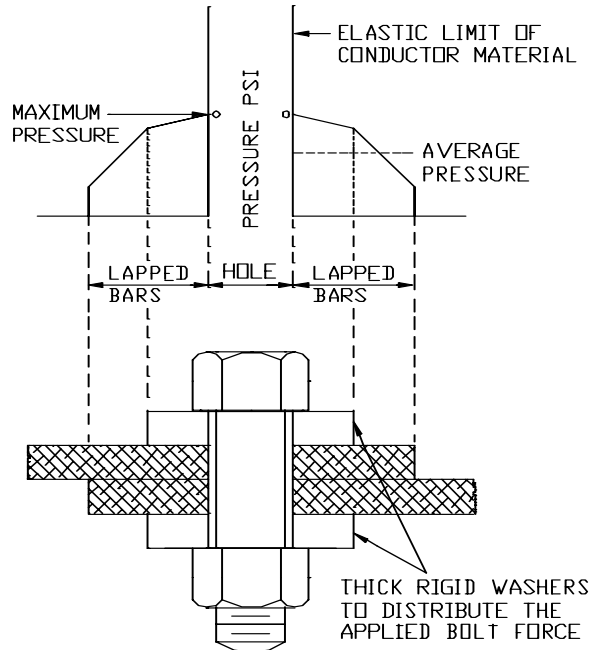

Figure 2: Distribution of forces in a bolted bus bar joint

Figure 2 shows the distribution of forces in a bolted bus bar joint. To obtain a low resistance bus bar joint, we must establish and maintain sufficient pressure, and distribute the pressure over a large area. Initially, the two bus bars mate at only a few peaks or high spots. As the bolt is tightened, the bus conductors begin to deform, bringing more of these peaks into contact. At the design pressure, there is a relatively larger contact area, so that there are a multitude of parallel electrical connections between the bars.

As shown in figure 2, the force is concentrated more heavily around the bolt hole. Since the pressure is highest in the vicinity of the bolt hole, the surface irregularities in this area are flattened out as the mating surfaces are forced into more intimate contact. The joint resistance in this area will be lower than elsewhere in the joint. As distance from the bolt hole increases, pressure decreases and joint resistance increases. Beyond the area defined by the washer, pressure decreases rapidly and little effective current carrying capacity results. From figure 2, we can see how the large diameter washers serve to distribute the clamping force more uniformly over a wider area than would be the case with a smaller washer, or none at all.

A properly designed bolted bus bar joint will allow the bus system to meet the temperature rise limits imposed by the ANSI standards, and will also have the thermal and mechanical capability to withstand the heat generated and forces imposed under the worst case short-circuit conditions.

T. W. (Ted) Olsen
 Manager, Technology